

Cleaning System

NIKE FX

POMPA PERISTALTICA PER DOSAGGIO DETERGENTE



Principali caratteristiche

- DOSAGGIO MANUALE REGOLABILE DA 0.15 A 15 LT/H
- IDEALE PER MACCHINE OPERATRICI A GETTONI
- ADATTO PER L'INIEZIONE DEI LIQUIDI AD ELEVATA VISCOSITA'
- GRADO DI PROTEZIONE IP 65
- FACILE INSTALLAZIONE E MANUTENZIONE
- ALIMENTAZIONE 100 ÷ 240 o 24 Vac 50/60hz, OPTIONAL 24VAC
- TUBAZIONE DELLA PERISTALTICA IN SANTOPRENE, EPDM O SILICONE Ø 6,25x10,5 mm
- PORTATA 15 L/h - PRESSIONE 100 kPa (1 bar - 14,5 psi)
- INTERRUTTORE ON/OFF

Cleaning System

Disegno quotato

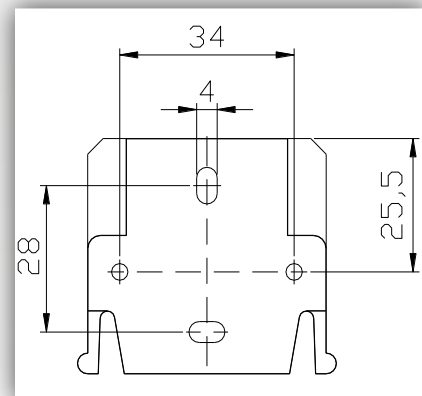
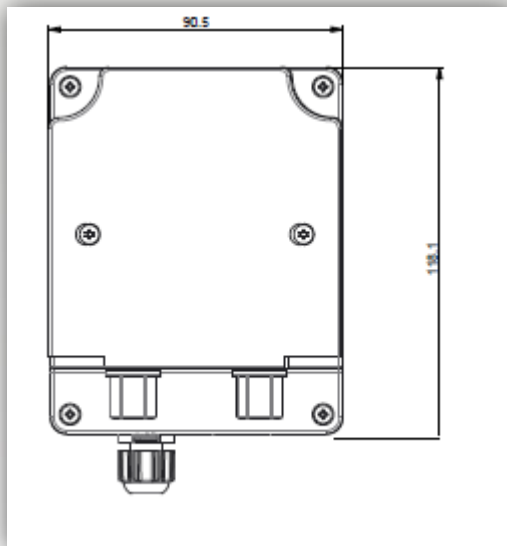
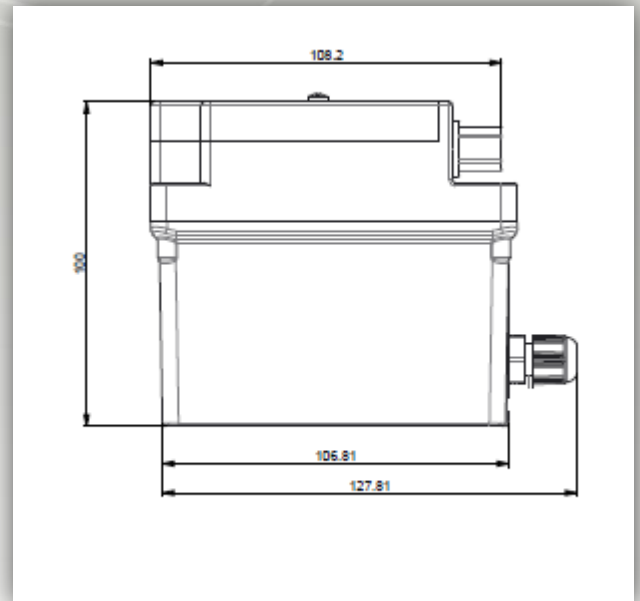
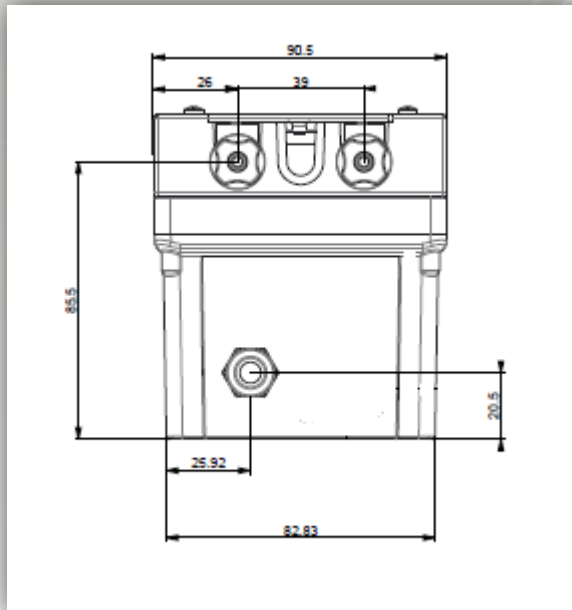

Cleaning System

Optional

