

# Water Treatment

## ATHENA BL

### POMPE DOSATRICI ELETTROMAGNETICHE



## Principali caratteristiche

- **CORPO POMPA PVDF** adatto per prodotti chimici usati nelle applicazioni industriali, nel trattamento acqua e nella potabilizzazione
- **SFERA CERAMICA** affidabilità del dosaggio e piena compatibilità chimica
- **DIAFRAMMA PTFE** resistenza e compatibilità con tutti i prodotti chimici
- **DOSAGGIO COSTANTE**
- **ALIMENTAZIONE** multi-tensione stabilizzata 100÷240 Vac 50/60 Hz con basso assorbimento
- **CONNESSIONE RAPIDA**
- **VALVOLA DI SPURGO MANUALE**
- **PROTEZIONE IP65**
- **PORTATA REGOLABILE** tramite una manopola sul pannello frontale
- **POWER-ON e LED ALLARME DI LIVELLO**
- **0÷20%, 0÷100%** doppia regolazione manuale di portata
- **Predisposizione di una sonda di livello con attacco rapido**

# Water Treatment



## Dati tecnici

LA MISURA DELLE PRESTAZIONI E' STATA FATTA A TEMPERATURA AMBIENTE, CON ACQUA, A 1,5 m DI ALTEZZA DI ASPIRAZIONE

PORTATE	PRESSIONE	CC/IMP.	CONNESSIONI	COLPI/MIN.	CCONSUMI	PESO	MODELLI
0,4 l/h	20 bar	0,06	4x6 - 4x7	120	14 watt	3 kg	<b>Athena basso flusso</b>
0,8 l/h	16 bar	0,11	4x6 - 4x7	120	14 watt	3 kg	
1,2 l/h	10 bar	0,16	4x6 - 4x7	120	14 watt	3 kg	
1,5 l/h	6 bar	0,21	4x6 - 4x7	120	14 watt	3 kg	
2,5 l/h	20 bar	0,35	4x6 - 4x7	120	14 watt	3 kg	<b>Athena 1</b>
3 l/h	18 bar	0,42	4x6 - 4x7	120	14 watt	3 kg	
4,2 l/h	14 bar	0,58	4x6 - 4x7	120	14 watt	3 kg	
7 l/h	8 bar	0,97	4x6 - 4x7	120	14 watt	3 kg	
3 l/h	12 bar	0,31	4x6	160	20 watt	3 kg	<b>Athena 2</b>
4 l/h	10 bar	0,42	4x6	160	20 watt	3 kg	
5 l/h	8 bar	0,52	4x6	160	20 watt	3 kg	
8 l/h	2 bar	0,83	4x6	160	20 watt	3 kg	
7 l/h	16 bar	0,39	4x6	300	40 watt	4 kg	<b>Athena 3</b>
10 l/h	10 bar	0,56	4x6	300	40 watt	4 kg	
15 l/h	5 bar	0,83	4x6	300	40 watt	4 kg	
18 l/h	1 bar	1,00	4x6	300	40 watt	4 kg	
20 l/h	5 bar	1,11	8x12	300	40 watt	4 kg	<b>Athena 4</b>
32 l/h	4 bar	1,78	8x12	300	40 watt	4 kg	
62 l/h	2 bar	3,44	8x12	300	40 watt	4 kg	
110 l/h	0,1 bar	6,11	8x12	300	40 watt	4 kg	

# Water Treatment

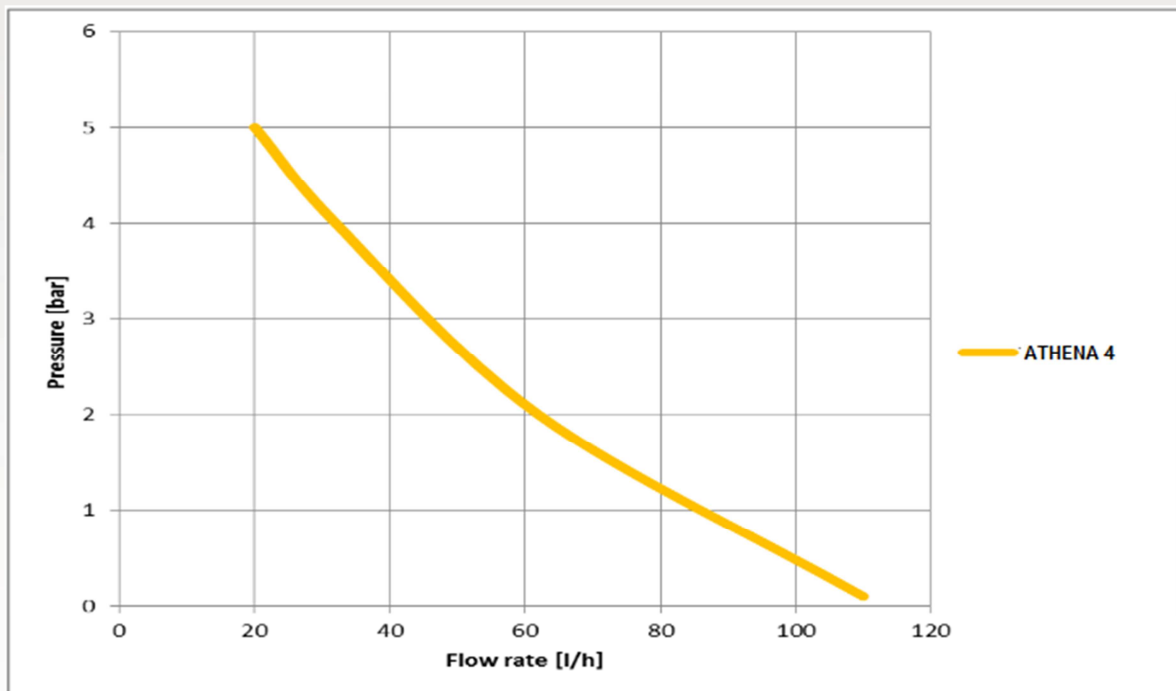
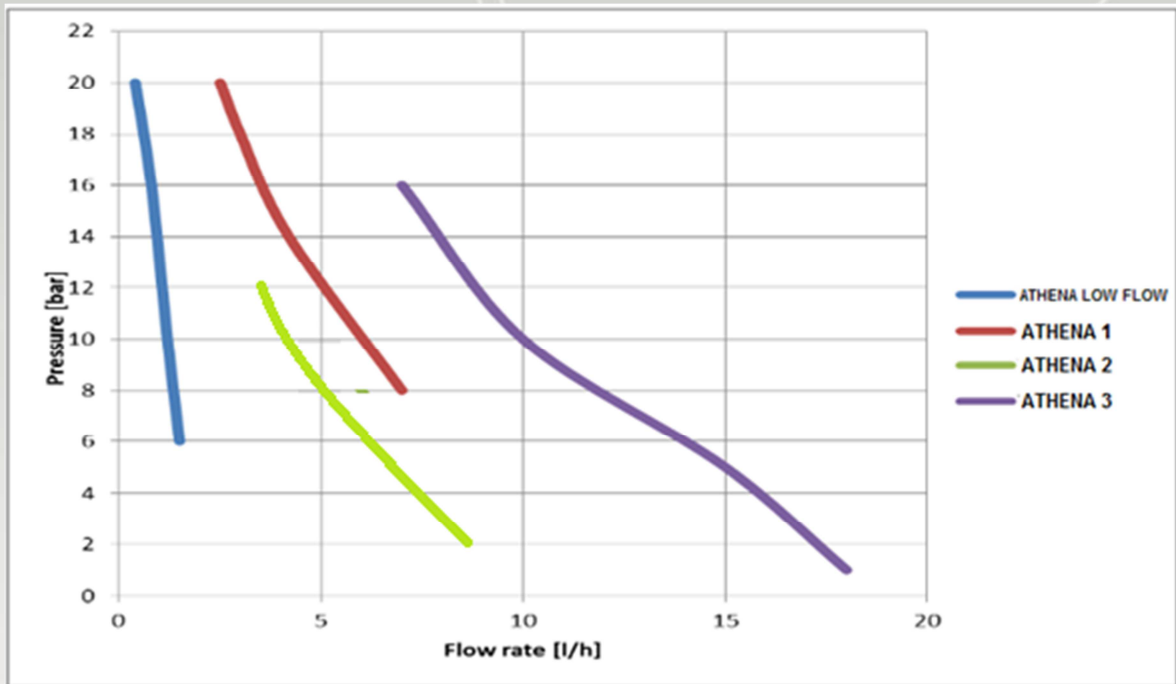

# Water Treatment



## Principali applicazioni

- Trattamenti industria galvanotecnica, decapaggio, sgrassaggio e trattamenti dei metalli in generale
- Torre di raffreddamento
- Acqua potabile
- Osmosi inversa
- Industria della carta
- Industria ceramica

## Esempio di installazione



# Water Treatment



## Kit di installazione



## Accessori

<b>AC.VSA (ATHENA.1 .2 .3)</b>	
	<ul style="list-style-type: none"> <li>• Corpo pompa in pvdf con autospurgo</li> <li>• Riduzione della portata in funzione della quantità di gas presente</li> </ul>

<b>AC.VM PVDF</b>	
	<ul style="list-style-type: none"> <li>• Valvola multifunzione, antisifone, contropressione, sicurezza</li> <li>• Corpo in PVDF, membrana in PTFE</li> <li>• Pressione regolabile 0÷5 bar</li> <li>• Pressione di sfioro 0÷18 bar</li> </ul>

<b>AC.VS</b>	
	<ul style="list-style-type: none"> <li>• Valvola di contropressione regolabile fino a 10 bar</li> <li>• Membrana in PTFE</li> </ul>

<b>AC.ST</b>	
	<ul style="list-style-type: none"> <li>• Staffa per il montaggio orizzontale a basamento</li> </ul>

<b>PRIMING AID</b>	<b>Capacità</b>
	<ul style="list-style-type: none"> <li>• Capacità: 300 ml</li> <li>• Corpo in: PVC</li> <li>• Tenute in: FPM</li> <li>• Connessioni: 4x6mm-8x12mm</li> </ul>

<b>AC.VIE</b>	
	<ul style="list-style-type: none"> <li>• Valvola iniezione estraibile PVC 1/2" g.m. IN - 1/2" g.m. OUT</li> </ul>
	<ul style="list-style-type: none"> <li>• Valvola iniezione estraibile con intercettatore PVC 1/2" g.m. IN - 1/2" g.m. OUT</li> </ul>

<b>AC.SL</b>	
	<ul style="list-style-type: none"> <li>• Sonda di livello fornita di cavo polare (2 mt) con staffa</li> </ul>

# Water Treatment



## Dimensioni

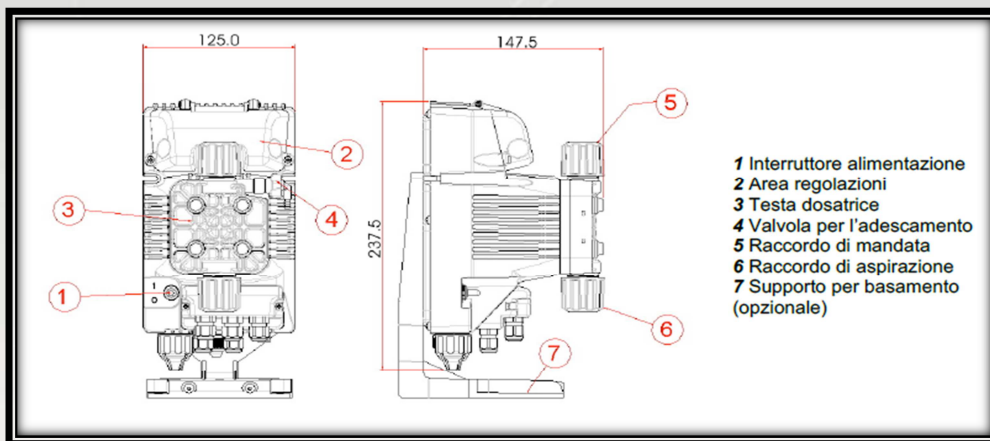

## Connessione Idraulica

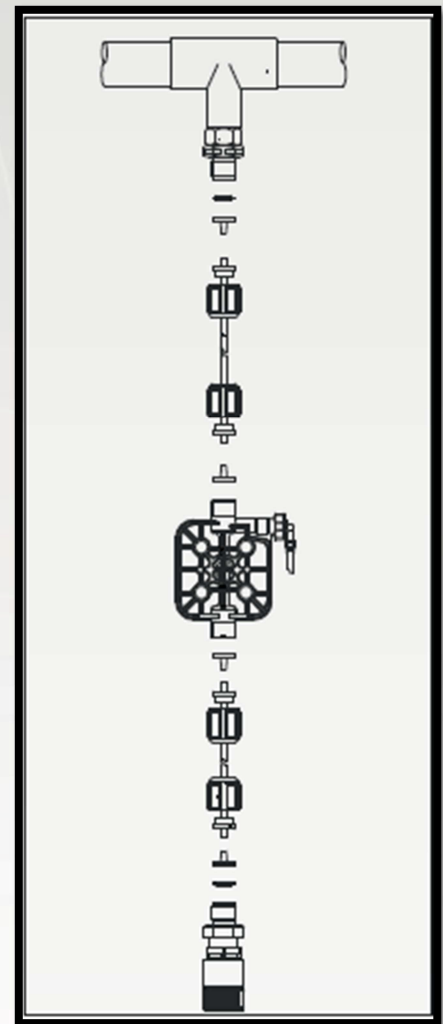

## Dima di foratura

