

# Water Treatment



## GEMINI P30

### POMPE PNEUMATICHE



## Caratteristiche principali

- **MATERIALI DI COSTRUZIONE: PP, POMC, PVDF, AISI 316, ALLUMINIO**
- **CAPACITÀ AUTOADESCANTE A SECCO FINO A 6M**
- **FUNZIONAMENTO A SECCO ILLIMITATO**
- **CIRCUITO PNEUMATICO ANTISTALLO E DI FACILE MANUTENZIONE**
- **POSSIBILITÀ DI REGOLAZIONE DI: PORTATA, PREVALENZA E VELOCITÀ.**
- **MOLTEPLICI VARIANTI DI INSTALLAZIONI E CONFIGURAZIONI**
- **CERTIFICAZIONI ATEX PER ZONA 1 E 2 IN TUTTE LE VERSIONI**
- **COPERCHIO DI SCARICO CON CONNESSIONI PER VARI UTILIZZI**
- **POMPAGGIO DI FLUIDI IN PRESENZA DI PARTI SOLIDE ED IN SOSPENSIONE**
- **POSSIBILITÀ DI FUNZIONARE A SECCO SENZA SUBIRE DANNI**

# Water Treatment



## Principali applicazioni

- **Produzione chimica e petrolchimica e trasformazione di prodotti di base**
- **Industria tessile**
- **Industria alimentare, conserviera, casearia, delle bevande ed oli**
- **Industria ecologica, smaltimento rifiuti , trattamento di fumi e acque e industria di stampa flessografica e fotografica**
- **Industria conciaria**
- **Estrazione**
- **Industria automobilistica e automotiva in generale**
- **Industria ceramica, vetro e porcellana**
- **Industria orafa**
- **Industria cartaria**
- **Industria elettronica e circuiti stampati**
- **Industria galvanotecnica, decappaggio, sgrassaggio e trattamento dei metalli in generale**
- **Industria di colori e vernici**
- **Industria petrolifera**
- **Industria per la produzione di fertilizzanti**
- **Industria metallurgica**
- **Industria del biodiesel , produzione di energia e accumulatori**
- **Industria dei detersivi industriali**
- **Industria farmaceutica**

## Esempi di installazioni



# Water Treatment



## Dimensioni

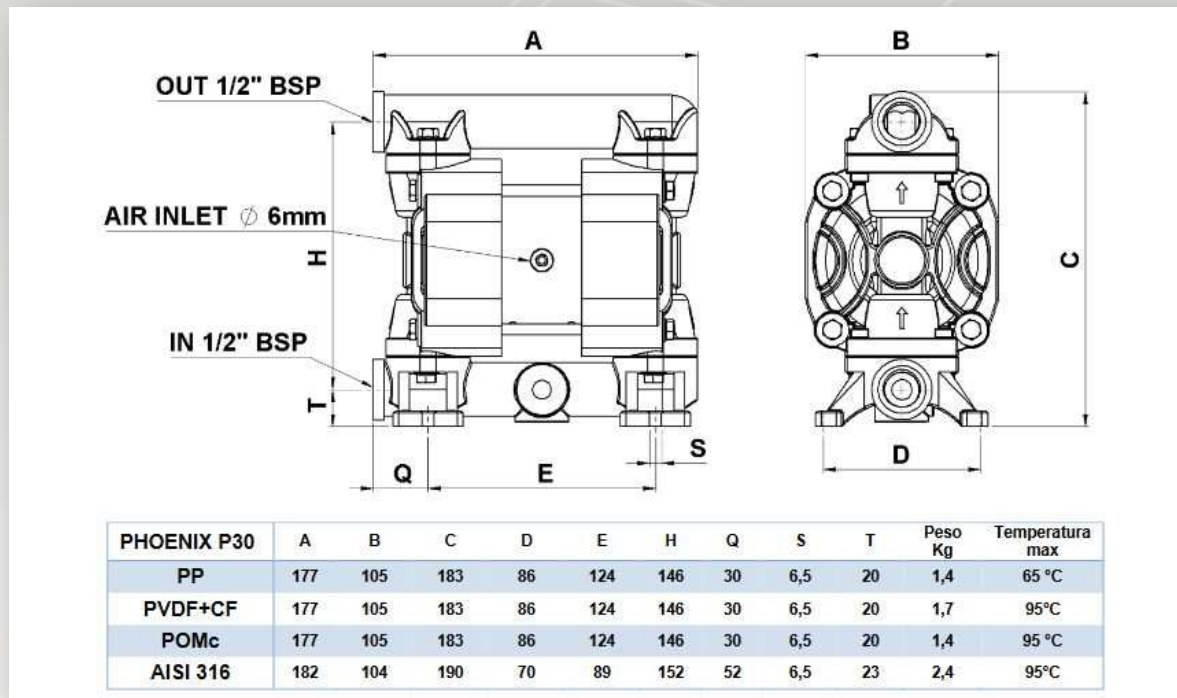

## Specifiche

- CONNESSIONI: 1/2" BSP**
- ATTACCO ARIA: 6mm**
- PORTATA MASSIMA: 35 lt/min**
- PRESSIONE MASSIMA: 8 Bar**
- PREVALENZA MASSIMA: 80 Mt**
- MAX ASPIRAZIONE NEG. A SECCO: 5 mt**
- MAX ASPIRAZIONE NEG. INVASATA: 9,8 mt**
- PASSAGGIO SOLIDI: 3,5 mm**
- RUMOROSITA': 65 dB**
- CILINDRATA PER CICLO: 50cc**
- VISCOSITA': 15.000 cps**

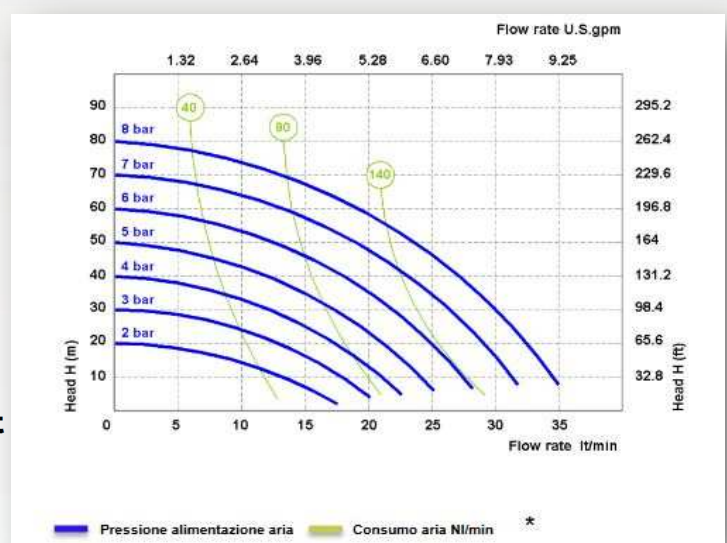

# Water Treatment

## Accessori



### AIR REGULATION KIT

Adjust and set air pressure and air flow-rate with a filter regulator, pressure gauge and air valve unit.



### SWITCH VALVES

Remotely start and stop with a solenoid or pneumatic valve for the pump's air.



### STROKE COUNTER

Count the number of strokes, connected to a control. It allows various type of monitoring.



### DIAPHRAGM FAILURE DETECTION

The Electronic Leak Detector provide a signal via warning lights, an audible alarm, and the pump can be shut down.



### PNEUMATIC BATCH CONTROL "START & STOP"

Pneumatic batcher can control any pump allowing you to set the cycles amount.



### BASKET STRAINER FILTERS IN PP

Installed on the suction of the pumps, protects them from suspended solids and impurity.



### INOX TROLLEY

It makes transportable pumps



### ANTI VIBRATION FEET KIT

Reduces physical vibration from AOD pump operation.



### PP, PVDF, ALU, SS NOZZLE

Dispenser to delivery control and batching.



### VALVES, FITTINGS AND CONNECTIONS IN PP, PVC, INOX



### REINFORCED PVC HOSE

With metal reinforcement for suction/discharge, also food-grade.



### FLANGE CONNECTION KIT

Adapt a pump from BSP type connection to flanges with this kit.